

Every pump tested in water to ensure pump meets performance curve.



FEATURES/BENEFITS

PERFORMANCE

- Heads up to 34' TDH
- Flows up to 109 GPM

MOTOR

- High efficient, 115v or 230v, oil filled, permanent split capacitor motor with upper and lower ball bearings and thermal overload protection
- Constant bearing lubrication
 - Maximum motor cooling
 - Runs cooler and lasts longer
 - Internal overload protection
 - Quiet operation
 - Fasteners and shaft made from rugged, corrosion resistant stainless steel

SEAL DESIGN

- Type 21 inboard seal design with secondary exclusion seal
- Rotating components of seal are in the motor housing, being lubricated by the motor oil preventing foreign matter from wrapping around the seal components
 - Seal will last longer if the pump runs dry
 - Secondary exclusion seal keeps debris from entering the seal cavity

IMPELLER DESIGN

- Non-clog style, cast-iron vortex impeller
- Designed to help reduce clogging by foreign material

POWER CORD

- Sealed entry quick disconnect power cords
- Prevents water from entering the motor housing through a cut cord
 - Easy to replace in the field
 - Available in lengths up to 100'

SWITCH

- Piggy-back switch design
- Defective switches can be diagnosed over the phone
 - Pump can be operated manually or supplied with other piggy-back switches
 - Switch can be replaced without having to replace the pump

APPLICATIONS

Basements, dewatering, septic systems, sewage lift stations, add-a-baths and truck docks



1/2 HP submersible pumps that handle up to 2" solids with 2" discharge

PERFORMANCE CURVE

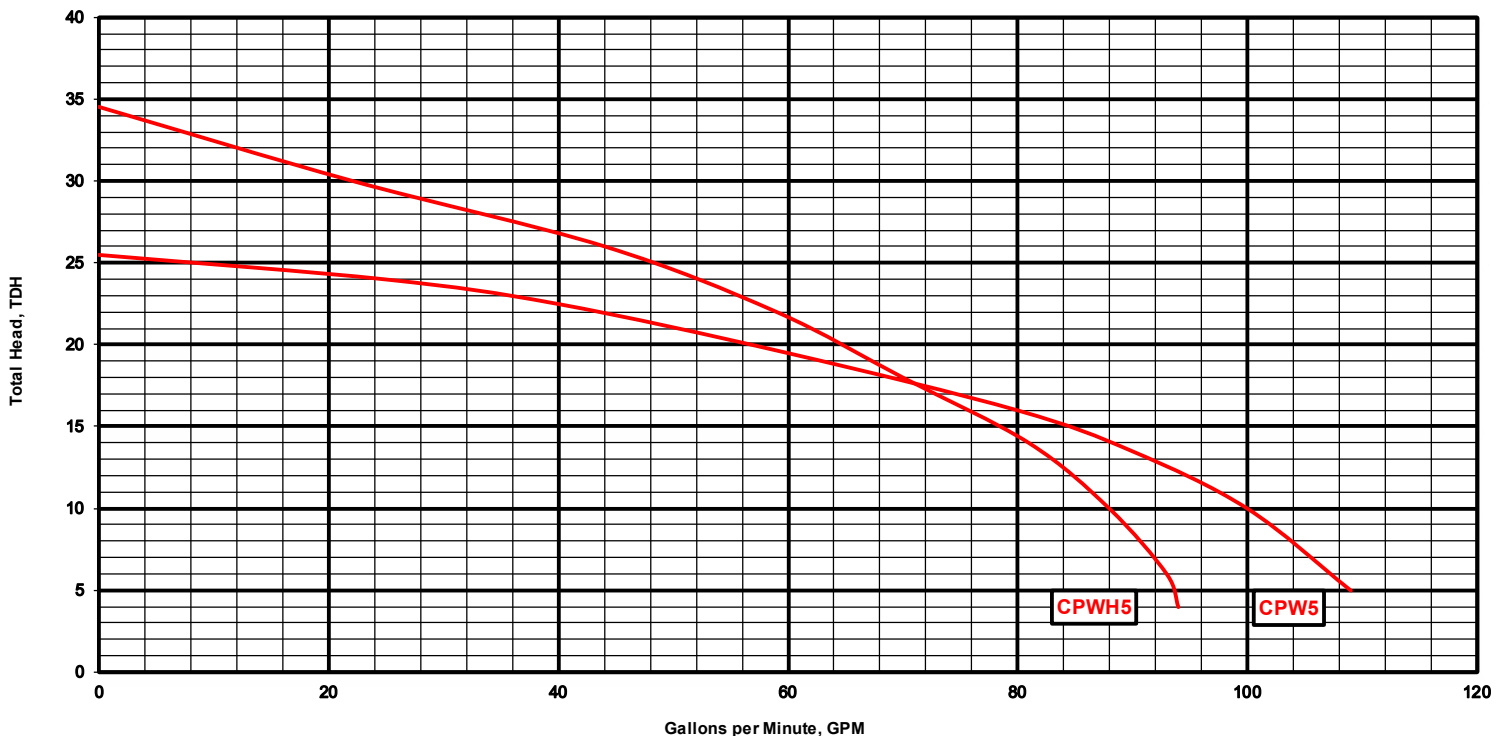

TECHNICAL DATA

DISCHARGE	2" NPT. vertical standard
SOLIDS HANDLING	2" CPW, 1-1/2" CPWH
LIQUID TEMPERATURE	140 Degrees F. (Intermittent)
MOTOR HOUSING	Cast Iron
VOLUTE	Cast Iron
SEAL PLATE	Cast Iron
IMPELLER	Cast Iron / Vortex
SHAFT	Stainless Steel
SHAFT SEAL (SINGLE SEAL)	Inboard mechanical with secondary exclusion V-Seal, carbon rotating face, ceramic stationary face, Buna-N elastomer, 300 series stainless steel hardware
BEARINGS (UPPER & LOWER)	Single row, ball, oil lubricated
HARDWARE	300 Series stainless steel
O-RINGS	Buna-N
CORD	10' Length standard. Up to 100' available. (UL/CUL) Listed 16 AWG, Type SJTW
MOTOR (SINGLE PHASE)	1/2 HP 3450 RPM, 60 Hz, NEMA L Includes overload protection in the motor, oil filled, class B permanent split capacitor
WEIGHT	37 lbs. (Manual)

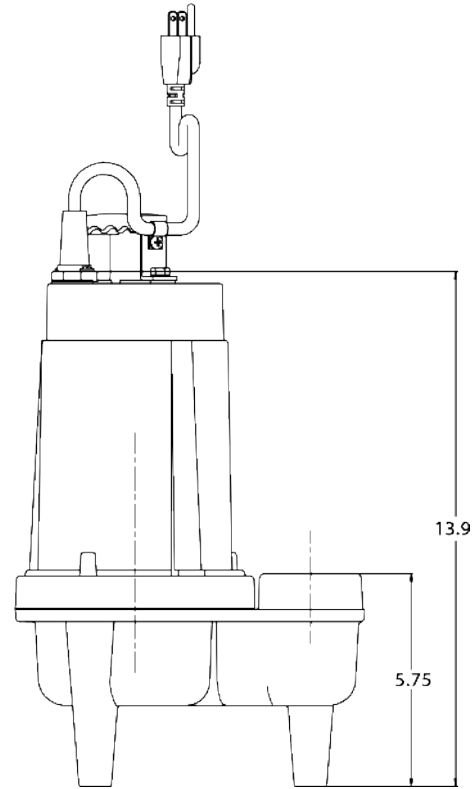
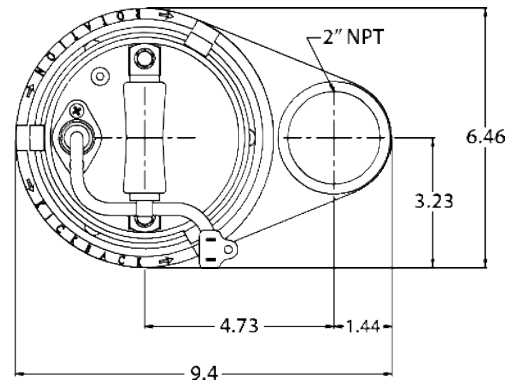

MODEL(S) INFORMATION

MODEL	HP	VOLTS	PHASE	AMPS	CORD LENGTH	SWITCH
CPW5-11 / CPWH5-11	1/2	115	1	11.5	10'	Manual
CPW5-12 / CPWH5-12	1/2	115	1	11.5	20'	Manual
CPW5-13 / CPWH5-13	1/2	115	1	11.5	30'	Manual
CPW5-15 / CPWH5-15	1/2	115	1	11.5	50'	Manual
CPWA5-11 / CPWH5A-11	1/2	115	1	11.5	10'	Wide-Angle Float
CPW5A-12 / CPWH5A-12	1/2	115	1	11.5	20'	Wide-Angle Float
CPW5A-13 / CPWH5A-13	1/2	115	1	11.5	30'	Wide-Angle Float
CPW5V-11 / CPWH5V-11	1/2	115	1	11.5	10'	Vertical Float
CPW5V-12 / CPWH5V-12	1/2	115	1	11.5	20'	Vertical Float
CPW5V-13 / CPWH5V-13	1/2	115	1	11.5	30'	Vertical Float
CPW5-22 / CPWH5-22	1/2	230	1	5.75	20'	Manual
CPW5A-22 / CPWH5A-22	1/2	230	1	5.75	20'	Wide-Angle Float
CPW5V-22 / CPWH5V-22	1/2	230	1	5.75	20'	Vertical Float