

Infiltrator IM-Series Tank Buoyancy Control Guidance

MARCH 2015



Before you Begin

This document presents recommended buoyancy control methods for Infiltrator Systems Inc.'s (Infiltrator's) IM-Series tanks. Tank buoyancy control methods must be implemented according to state and/or local regulations, which may supersede the guidelines in this document. If unsure of the requirements for a particular site, contact the local health department or permitting authority.

This document provides procedures to determine if tank buoyancy control is required based on site conditions. Please obtain the following information to determine if control is necessary and what methods are applicable:

- Infiltrator tank model
- Maximum height of water outside the tank and above the tank bottom elevation
- Depth of soil cover over the tank top

Once tank buoyancy control measures are determined to be required and a method has been selected and implemented, refer to Infiltrator IM-Series Tank Installation Instructions and Riser Connection Guidance documents, as applicable, for completing the installation.

How to Use this Document

1. Become familiar with the descriptions in the Compatible Devices and Products section.
2. Verify that the water level outside the tank is below the outlet pipe saddle height using Step 1, Tables 1 and 2, and Figure 1.
3. Determine if buoyancy control is required using Step 1, Table 2. If buoyancy control is necessary, proceed to Step 2.
2. Use the respective table for the tank model from Step 2, Table 2 to determine the appropriate buoyancy control methods for the site conditions.
5. Once a preferred buoyancy control method is selected, follow the procedures for implementation provided in Step 3.

Parts and Supplies

The parts and supplies necessary are to be purchased separately from the tank. All parts and supplies are either commercially available or available through Infiltrator's network of tank distributors. Some parts may require fabrication on site using common construction practices.

Compatible Devices and Products

Infiltrator tanks are compatible with the following products for buoyancy control:

- **Tie-down straps:** high-tensile-strength webbing, 10,000 lb (4,500 kg) minimum capacity, nylon or polyester, with corrosion-resistant hardware.
- **Concrete deadmen anchors:** concrete-filled plastic half pipe, precast parking bumper, precast traffic barrier, or poured block.
- **Helical anchors:** Chance™ No-Wrench Screw Anchors with minimum 6-inch (150 mm) diameter, Class 7 or equal.

Tie-Down Straps

Straps are commercially available in varying lengths and with assorted hardware and tightening options. Nylon or polyester strapping with minimum 10,000 lb (4,500 kg) capacity is required for buoyancy control use with Infiltrator tanks. Place straps up and over the tank at specified locations only (see Figure 5). Tighten straps snugly with a ratchet or turnbuckle system to remove all slack and slightly pre-load the system. All connections, fittings, and hardware must be corrosion resistant or coated with epoxy or other corrosion-resistant materials to inhibit deterioration in the subsurface environment. Consider encapsulating such components in heat-shrink tubing or painting on additional corrosion-resistant coatings prior to burial.



Concrete Deadmen Anchors

Recommended concrete deadmen anchors include filled plastic half pipe, precast parking bumpers and traffic barriers, and poured blocks. The weight of the deadmen anchors combined with the weight of soil above them provides buoyancy control when properly secured. Deadmen anchors are placed at the bottom of the tank excavation on opposite sides of the tank. The deadmen anchors are fastened to each other with tie-down straps placed up and over the tank at the locations specified for each tank model (see Figure 5).

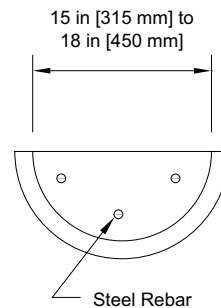

Concrete-filled plastic half pipe

Use Schedule 40 PVC plastic pipe having a minimum inside diameter of 15 inches (375 mm) or HDPE corrugated pipe having a minimum inside diameter of 18 inches (450 mm) cut in half lengthwise. Fill with concrete having a minimum unit weight of 145 lbs/ft³ (2.32 metric tons/m³) reinforced with three equally spaced 40-grade, 1/2-inch (13 mm) diameter steel bars. Weight is 61 lbs/ft (91 kg/m) minimum.

Concrete parking bumper

Use commercially available steel-reinforced parking bumpers with typical dimensions of 12 inches wide by 6 inches high (300 mm x 150 mm). Weight is 58 lbs/foot (86 kg/m) minimum.

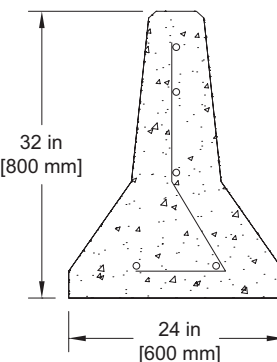
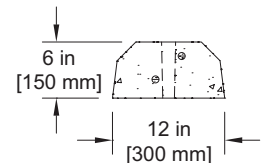

Concrete traffic barrier

Use commercially available steel-reinforced concrete traffic barrier or equivalent. Typical dimensions include a 24-inch-wide base tapering to a 6-inch-wide top, with a height of approximately 32 inches (600 mm x 150 mm x 800 mm). Weight is 390 lbs/foot (580 kg/m) minimum.

Poured Blocks

Concrete precasters can pour blocks of various dimensions and weights. Blocks are often an affordable option if they satisfy the weight requirements for use as buoyancy control (see Table 2 and the Supplemental Force section of Step 2 for more information).

Helical Anchors

Chance™ No-Wrench Screw Anchors with a 6-inch (150 mm) diameter flight, Class 7, or equal. These anchors rely on the shear strength of the soil combined with the weight of the soil above the anchor flight to provide holding strength. Proper installation is to 4 feet (1.2 m) below the bottom of the tank excavation and to within 5° of alignment with the webbing load. Determine the proper locations for anchor installation to ensure that tie-down straps will be aligned properly for each tank model (see Step 3: Implementation), and follow anchor manufacturer installation instructions.

Typical working torque:
¾" Rod 400 ft. lbs. (542 N-m)
1" Rod 1,000 ft. lbs. (1,356 N-m)
1¼" Rod 2,300 ft. lbs. (3,118 N-m)



Step 1 – Determine Need for Buoyancy Control

Required information: the maximum height of water outside the tank and above the tank bottom AND the depth of soil cover above the tank top. Tank buoyancy control may be required if the water level outside the tank has the potential to rise 30 inches (750 mm) or more above the bottom of the tank, AND less than 12 inches (300 mm) of soil cover is to be placed as backfill over the tank top. Otherwise, no buoyancy control is required.

Allowable Subsurface Water Elevation

Groundwater elevation, groundwater table, and water table are terms for the subsurface condition where water is held in the subsurface soil pores or rock. The seasonal high groundwater elevation represents the highest point the water table has the potential to reach at any time of the year, and is not necessarily the level at which groundwater may be observed seeping from the soil at the time of tank installation. In general, a qualified soil evaluator or engineer can estimate the seasonal high groundwater elevation from careful examination of the soil profile.

Under certain conditions, a perched water table may be present in the subsurface. A perched water table occurs where there is an impermeable or low-permeability soil that causes water to be present in the soil pores above the main water table. A perched water table elevation may exceed the seasonal high elevation of the main water table. The vertical position of the tank must account for both the seasonal high groundwater table and any existing or future perched water table condition. **Verify that the subsurface water level will not exceed the height of the outlet pipe saddle of the tank, as show in Tables 1 and Figure 1.**

Table 1 Instructions

1. In the left-hand column of Table 1, locate the row corresponding to the height of the water elevation outside the tank and above the tank bottom (Parameter I) for the site conditions. See Figure 2.
2. Follow that row to the right until reaching the column corresponding to the depth of soil cover proposed above the tank top (Parameter II). See Figure 2.
3. If the tank model is listed in that cell, then buoyancy control is required (proceed to Step 2). If the tank model is not listed in that cell, then no buoyancy control is required.
4. The tank shall not be installed where the water level outside the tank exceeds the height of the outlet pipe saddle.

Table 1: Infiltrator tank models¹ and conditions requiring buoyancy control

Parameter I: Water height ² above tank bottom		Parameter II: Soil cover depth above tank top ³	
		A	B
		6 in (150 mm) to 12 in (300 mm)	Above 12 in (300mm)
1	Above outlet pipe saddle ⁴ (greater than 43")	Do not install	Do not install
2	36" (900 mm) to 43" (1075 mm) to outlet pipe saddle	All models	Not Required
3	30" (750 mm) to 36" (900 mm)	IM-1530	Not Required
4	Less than 30" (750 mm)	Not Required	Not Required

Design Example

A contractor plans to install an IM-1060 tank where the water level outside the tank has the potential to rise to 37 inches (940 mm) above the tank bottom (Parameter I), and the design plan calls for 8 inches (200 mm) of soil cover above the top of the tank (Parameter II). In Step 1, Table 1, a 37-inch (940-mm) exterior water height corresponds to row 2 (36 inches [900 mm] to outlet pipe saddle) under Parameter I. The 8-inch (200-mm) soil cover corresponds to column A (6 inches [150 mm] to 12 inches [300 mm]) under Parameter II in Table 1. At the intersection of Parameter I, row 2 and Parameter II, column A, Cell 2A indicates "All models", meaning all tank models, including the IM-1060, require buoyancy control under these conditions. Referring to Step 2, Table 2, under the IM-1060 heading, Case 1 would apply for 37 inches (940 mm) of water above the bottom of tank and 8 inches (200 mm) of soil cover. Available options are as follows (see specific strapping and construction information under Step 3):

- If concrete block is specified to anchor the IM-1060, the total combined minimum weight of blocks placed on each side of the tank shall be 2,700 pounds (1,225 kg). The size and shape can be determined by locally available materials. Connect using two straps.
- For concrete-filled half pipe and concrete traffic barrier, the minimum length on each side of the tank would be 4.2 feet (1.3 m), while at least 4.5 feet (1.4 m) of concrete parking bumper would be required. These controls would be connected with two straps, ensuring that the control extends a minimum of 6 inches (150 mm) beyond the strap positions (see Figure 3).
- If helical anchors were selected, a minimum of two 6-inch (150 mm) diameter anchors per side of tank (4 total) would be installed using two straps.

Figure 1: Water Elevation

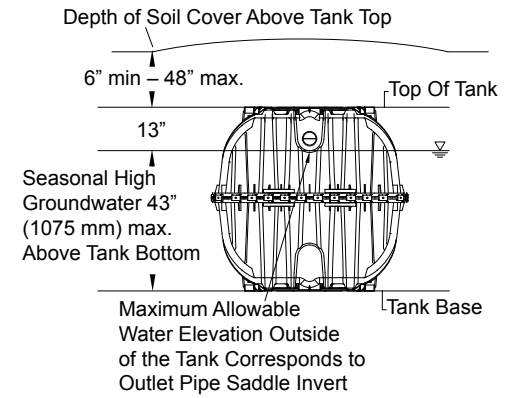
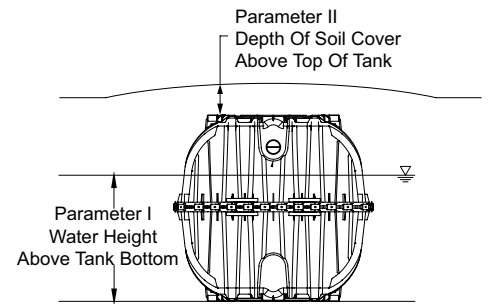

Figure 2: Buoyancy Control Parameters



NOTES:

1. Infiltrator tank models include: IM-540, IM-1060, and IM-1530.
2. Water height corresponds to seasonal high groundwater elevation or perched water elevation measured from bottom-of-tank elevation.
3. Minimum 6 inches soil cover backfill is required.
4. The tank shall not be installed where the water level outside the tank exceeds the height of the outlet pipe saddle.

Design Example Table 1: Infiltrator tank models and conditions requiring buoyancy control

Parameter I: Water height above tank bottom		Parameter II: Soil cover depth above tank top	
		A	B
		6 in (150 mm) to 12 in (300 mm)	Above 12 in (300 mm)
1	Above outlet pipe saddle	Do not install	Do not install
2	36" (900 mm) to 43" (1075 mm) to outlet pipe saddle	All models	Not Required
3	30 in (750 mm) to 36 in (900 mm)	IM-1530	Not Required
4	Less than 30 in (750 mm)	Not Required	Not Required

Step 2 – Determine Buoyancy Control Method

Step 2 is used if the Step 1 analysis shows that buoyancy control is required for the tank model and the conditions of installation. As before, the maximum height of the water outside of the tank and above the tank bottom AND the depth of soil cover above the tank top must be known for the installation conditions to complete Step 2.

Table 2 Instructions

For each tank model, find the Case row on the left side of the table that corresponds to both the water height (Parameter I) and soil cover measurements (Parameter II) for the tank installation conditions. Follow the row to the right for a listing of the appropriate buoyancy control methods for the installation conditions under each method description column. Refer to the Compatible Devices and Products and Step 3 – Implementation sections of this document for additional information.

Table 2: Buoyancy Control Selection

Case	Parameter I: Water height above tank bottom	Parameter II: Soil cover depth above tank top	Minimum supplemental force required ¹ (total, both tank sides)	Buoyancy Control Methods (minimum per side of tank)			
				Concrete-filled half pipe (min. length/side)	Concrete parking bumpers (min. length/side)	Concrete traffic barriers (min. length/side)	Helical anchors (min. no./side)
IM-540							
1	36 in (900 mm) to outlet pipe saddle ²	6 in (150 mm) to 12 in (300 mm)	2,200 lbs (1,000 kg)	3.8 ft (1.2 m)	3.8 ft (1.2 m)	3.8 ft (1.2 m)	2
IM-1060							
1	36 in (900 mm) to outlet pipe saddle ²	6 in (150 mm) to 12 in (300 mm)	2,700 lbs (1,225 kg)	4.2 ft (1.3 m)	4.5 ft (1.4 m)	4.2 ft (1.3 m)	2
IM-1530							
1	30 in (750 mm) to outlet pipe saddle ²	6 in (150 mm) to 12 in (300 mm)	4,300 lbs (1,955 kg)	6.3 ft (2.0 m)	6.5 ft (2.0 m)	6.3 ft (2.0 m)	2

NOTES:

1. See Supplemental Force discussion below.
2. IM-Series outlet pipe saddle height is 43 inches (1,075 mm) above tank bottom.

Supplemental Force

The minimum supplemental downward force required is included in Table 3 to allow custom buoyancy control methods. These values include a factor of safety of 1.5 applied to the calculated force required to restrain the tank. Custom-designed buoyancy control methods shall consider saturated conditions. So long as buoyancy control is provided that supplies the minimum weight listed in the table (for poured-concrete blocks or other methods designed by third parties), the tanks will be stable for the water height outside the tank and above the tank bottom and corresponding soil cover conditions. All Infiltrator strapping and fastening recommendations would still apply for custom-designed buoyancy control methods. Contact Infiltrator's Technical Services Department with any questions regarding supplemental force requirements.

Step 3 – Implementation

Effective buoyancy control of Infiltrator tanks requires careful preparation, thorough excavation, precise placement, secure strapping and proper backfilling, as described and illustrated below.

Excavation Requirements

It is recommended that the excavation width provide a minimum of 36 inches (900 mm) clearance beyond the tank on all sides when utilizing buoyancy control. This will allow sufficient space within the excavation to place deadmen anchors and fasten strapping. The excavation should provide a minimum of 48 inches (1,200 mm) when using Chance™ No-Wrench Screw Anchors to allow for room to properly install the screw anchors. The actual excavation size shall be determined by the installer. Refer to Infiltrator IM- Series Tank Installation Instructions for additional excavation procedures.

Concrete-filled Half Pipe Construction

Concrete-filled half pipe shall be supported with soil or other stabilizing means below the pipe haunches prior to concrete placement. The stabilization shall prevent the pipe from rolling during placement and curing of the concrete. Concrete shall be allowed to cure for a minimum of one day prior to tank backfilling.

Placement of Deadmen and Anchors

Concrete deadman anchors are to be installed at the bottom of the tank excavation, parallel to the long axis of the tank (see Figure 3).

Figure 3: Plan View

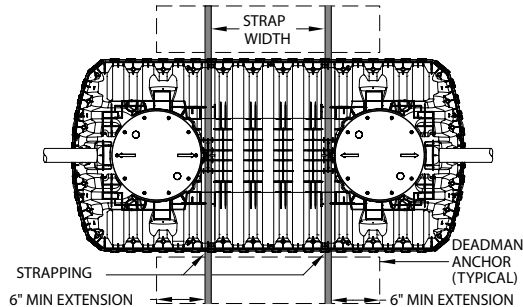

The deadmen should be placed close to, but not touching, the tank on both sides of the tank to allow the placement of backfill between the deadman anchor and tank sidewall (see Figure 4).

Figure 4: Section View

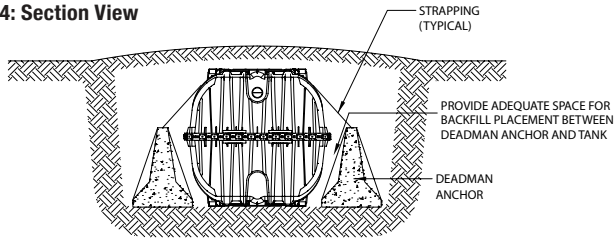

Helical anchors should be installed so that the eye loop is level with the bottom of the tank excavation. They must be in line with the tank model strapping locations (see Figure 5) or lifting lugs, as appropriate. Anchors must also be installed at such a distance from and angle to the tank so that the strapping is within 5° of alignment with the anchor shaft per manufacturer's recommendations.

Figure 5: Strap Positioning

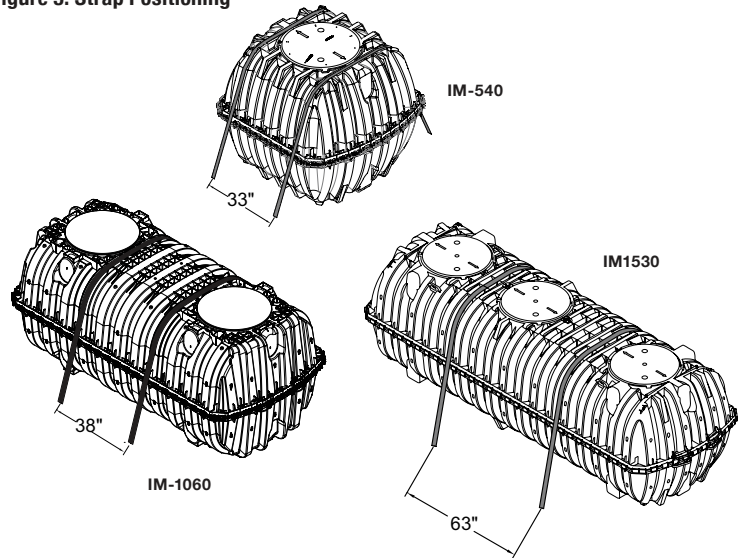

Strapping

Preparation and fastening of webbing to/over the tanks is critical for tank stability under constant and fluctuating water conditions both inside and outside the tank. Straps must be placed at the specified strapping locations for each model as illustrated in Figure 5. The IM-Series tank strapping locations correspond to structurally reinforced areas of the tank body. Straps must never be placed over access openings, lids, or inlet/outlet piping. Straps must be tightened with a ratchet or turnbuckle system to remove slack and slightly pre-load the system.

STRAPPING NOTES:

1. The buoyancy control shall be centered across the straps (excludes helical anchors). The control shall extend a minimum of 6 inches (150 mm) beyond the maximum strap width (see Figures 3 and 5).
2. The minimum deadman length corresponds to the tank model-specific strap width plus 12 inches (300 mm).

Backfill and Cover

Place backfill between deadman anchor and tank sidewall to fully fill void and tank body corrugations. A minimum 6" layer (150 mm) of suitable cover material is required over all Infiltrator tank installations. Mound cover to direct surface water drainage away from the tank excavation footprint. Establish a strong stand of erosion-resistant vegetation. Refer to Infiltrator IM-Series Tank Installation Instructions for complete backfilling and cover procedures.

General Specifications

- Prior to ground disturbance, check for subsurface obstructions and utilities in conformance with applicable requirements.
- Excavations shall conform to applicable safety regulations.
- Follow manufacturer instructions for all products and devices used for Infiltrator tank buoyancy control.
- Buoyancy control methods described herein do not account for unanticipated conditions such as surface flooding or other natural disasters, unintended removal of cover fill over tank, etc.
- Buoyancy control methods described herein are recommendations only; consult a professional engineer if desired.



4 Business Park Road
P.O. Box 768
Old Saybrook, CT 06475
860-577-7000 • Fax 860-577-7001
1-800-221-4436
www.infiltratorsystems.com