

Installation - Tank & Aerator J-500PLT – 800 PLT Series

NSF LISTED PLANTS

These instructions apply to J-500PLT – 800PLT plants. This series includes a 500, 750 and 800 GPD plant.

J-500 PLT – 800 PLT plants have been tested and meet NSF Standard 40 criteria for a Class I NSF Listing.

J-500 PLT – 800 PLT media installation is done by the distributor before the tank is delivered. There are 2 different sets of media that can be installed depending on total flow.

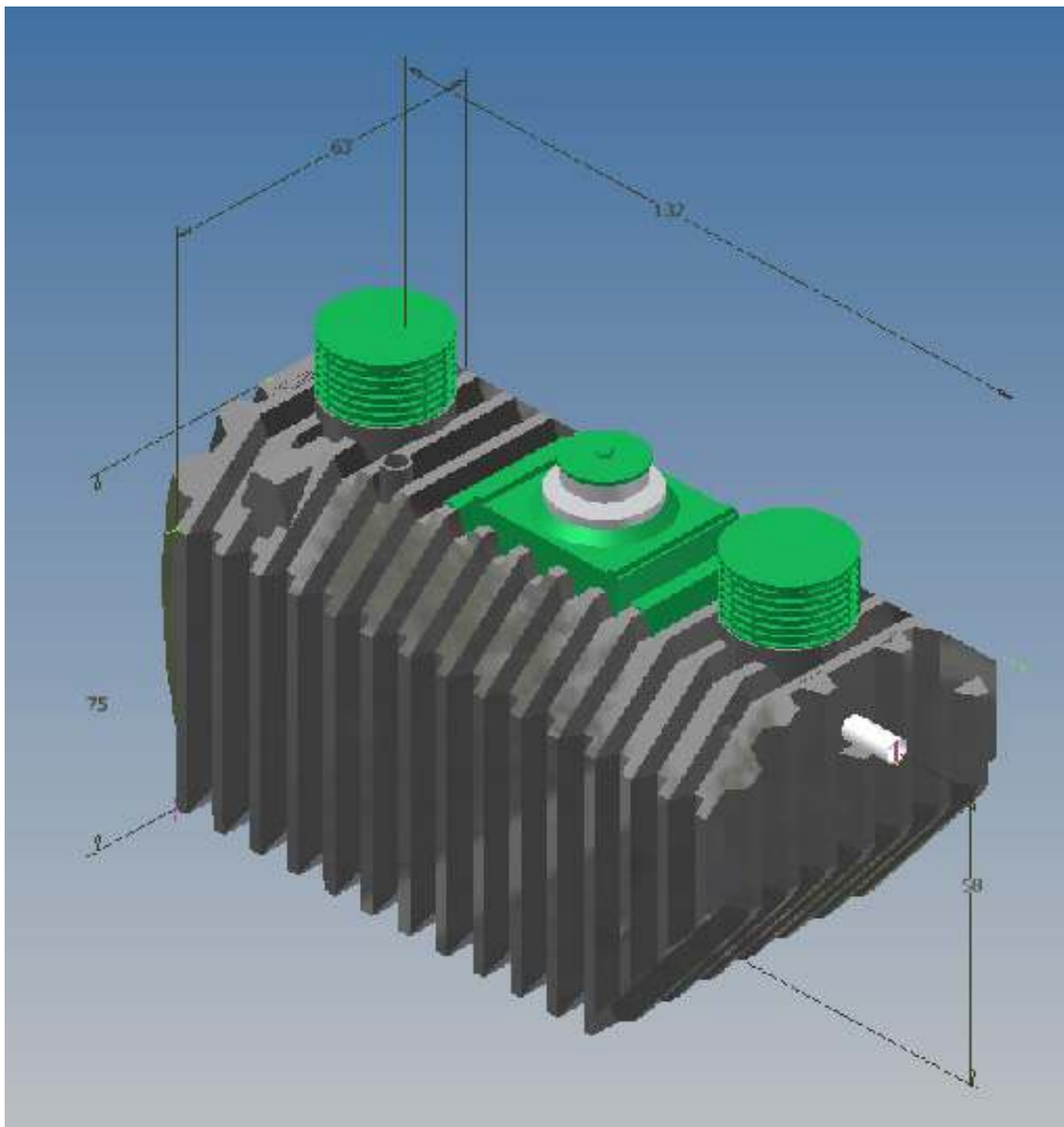

TANK INSTALLATION

IMPORTANT NOTES:

DO NOT:

1. Install tank in water saturated clay or in a high water table.
2. Install tank under areas where there is motorized traffic.
3. Backfill with clay soil

ALWAYS:

1. Completely fill the tank with water after installation.
2. Refill the tank with water immediately after pumping.

Only residential wastewater should be permitted to enter the system. The plant is not designed to receive flow from footer drains or roof downspouts or other storm water sources. The system should be located in an area which provides protection of the air intake from snow, ice or debris which may accumulate.

It is important that all local and state laws and plumbing codes regarding the plant installation process be followed. Appropriate installation permits are required for all installations. Items such as the connection of plumbing fixtures to the tank inlet line, position of inlet and discharge lines, grade and any other aspects of plant or plant related plumbing should be checked with the appropriate contractors to make sure all work conforms to local and state regulations. A pre-construction conference with all interested parties is strongly suggested.

This system is not designed to be installed above ground. Special procedures are required for above ground or partially buried installations.

Location of the tank must be in accordance with Health Department regulations in accordance with site design plans. Ideal location will be on ground which will not flood, which provides adequate fall and allows installation of lines which are as short and straight as possible.

There are many considerations in proper installation of a tank and the most important of which is that the tank installation meets the Health Department's regulations.

Jet systems may only be installed by authorized installers, who must be present during all phases of installation.

ANTI-FLOTATION DEVICE:

Note: It may be necessary to secure the tank with anti-flotation devices. Refer to the J-500-800PLT Bouyancy Tech Sheet.

EXCAVATION:

1. Verify the excavation is free of sharp stones and debris. The excavation should be level.
2. Allow for 9" to 24" of earth cover over the top of the tank. (approx. 7'-8' depth)
3. There should be sufficient over dig to allow for at least 12" of clearance on all four sides of the tank. (approx. 7'x13')
4. Verify there is a solid earthen pad to sit the tank on. Consider using a compacted mixture of sand and gravel (6" minimum in soil and 12" minimum in rocky terrain). Clay soils are not suitable for supporting the tank.

TANK SETTING:

1. Verify the tank is free of damage that may have occurred during transportation.
2. Verify rubber gasket and plastic tee has been installed in the inlet and outlet ports on the tank.
3. Place the tank in the excavation site and level to within 1" end to end and side to side.
4. Install extension risers if necessary, be sure to seal with mastic sealing and appropriate hardware.

5. If required, attach additional aerator risers to the center cover. Seal with mastic sealing and appropriate hardware.
6. Install inlet and outlet sewer lines and seal in place. Sewer lines should be 4" diameter PVC.
7. Cover all openings.

BACKFILLING TANK:

1. Fill 1/3 of the tank with water before backfilling begins to ensure tank will not shift during process.
2. Begin to backfill under the sloped clarifier.
3. The sloped clarifier wall must be supported to reinforce the tank walls. A mixture of sand and/or gravel must be used to backfill the inlet and outlet side walls of the tank. Jet recommends the backfill mixture consist of material no larger than 1 1/2" in diameter. The backfill should be added while compacting every 12" to ensure all void space under the sloped walls and around the inlet side walls has been completely filled.
4. Once the tank has been backfilled to the center line (above the sloped wall) the upper half of the tank can be backfilled with suitable native, preferably loose, soil; **Never backfill with clay soils**. Be sure the backfill is free of rocks and sharp objects.
5. Tamp and compact backfill mixture under the inlet and outlet pipes.
6. Fill the tank with water to the outlet.
7. Test for Proper Drainage - Be sure tank is full to the flow line. Fill bathtub, laundry sinks, and any other fixtures that drain into system. Then, simultaneously drain all these fixtures and flush toilets. Observe any rise in water level of tank. If the water rises over 3" and does not go down immediately, inform contractor that aerator cannot be installed until this situation is corrected.
8. Backfill the rest of the excavation to a maximum of 24" above the top of the tank with earth fill material. The final grade should slope away from the tank to help with surface runoff.

AERATOR INSTALLATION

IMPORTANT

- When installing the aerator be extremely careful of aspirator shaft. It has a very critical straightness tolerance. Don't ever let it touch anything except liquid. Also remember that the fit between coupling and aspirator shaft is quite close. Be careful not to burr or dirty the ends of either part.
- Jet aerators have been carefully designed and built to give years of trouble-free operation. To assure this long, trouble-free life, it is absolutely necessary to carefully follow the aerator installation and handling instructions.
- Life of the aerator depends on a straight shaft. Never lift aerator by the shaft or subject the shaft to any bending, bumping, or strain. Never let the shaft contact anything but liquid.
- You can eliminate well over 50% of your service calls if you always inspect the system and test for proper drainage at installation time.
- Jet Floodproof model aerators are sealed to protect them from water damage by flooding. It is, however, not designed to operate under water. Do not disassemble it or remove plugs or bolts.
- The "Control Panel Installation and Users Manual" contain a wiring diagram and detailed wiring instructions. An electrical specification and requirements chart, is located on the inside of each Control Panel.

INSTALLATION STEPS

1. Turn Off Power - Turn the aerator Control Panel switch to "OFF". Next turn power that controls this circuit at main panel "OFF".
2. Check Aerator/Flow Line Measurements - Location of aerator to flow line is very important. Measure distance from ledge in the aerator riser to liquid level in tank. Tank must be full to flow line. If it is between 25" to 27", aerator location is correct. If it is not, aerator riser may not be installed correctly.
3. Check Vent Position - Check position of vent cap in cover. It must be installed in center of cover as shown in illustration. If vent cap is not centered, the outside-air-hose will bend and air to the aerator will be cut off.

4. Inspect Outlet - Inspect final discharge point of system to insure it is not and cannot become blocked. If there is a chance that it may become blocked in the future, inform owner and contractor that this situation must be corrected before you can install aerator. Tell them blockage will lead to improper drainage and repeated stoppages - this can be avoided by preventive action now. (DO NOT INSTALL AERATOR IF SUCH A SITUATION EXISTS.)
5. Unpack Aerator –
 - a. Remove all manuals and paperwork. These should be left with the system or given directly to the homeowner.
 - b. Carefully remove aspirator shaft. Slide foam restrictor onto shaft so that side of foam restrictor labeled “This side toward motor” faces away from aspirator. Set this down gently in a safe place.
 - c. Remove parts bag, owner’s manual, and aerator. Because the aerator fits tightly into carton, it helps to grip the bottom of carton with your feet when pulling it out.
 - d. Inspect all parts for shipping damage. Notify the carrier immediately if there is any damage.
 - e. When handling the shaft be careful not to burr the ends of the coupling and aspirator shaft because the fit is quite close.
 - f. Exposing aerator to severe cold, such as the back of a truck or an unheated storage area, could cause circuit breaker to trip when power is first applied due to the drag from cold bearing grease. To prevent this problem, place aerator in a warm area (cab of truck) for a short time before installation. After the aerator is initially started, cold weather will not affect its operation.
6. Electrical Connection - Before proceeding, make sure power is “OFF” at both the aerator Control Panel and at the main electrical panel in the house. Test all three leads of cable with a multi-meter to be sure power is “OFF”. Check the dimension of the underground cable to make sure it is not smaller than 23/64” x 11/64”. If it is smaller, the grommet will not be watertight.
 - a. Factory-installed cord & connector.
 - i. Install female half of electrical connector on end of cable, in mounting casting, coming from facility. Connect two halves of connector.
 - ii. Strip the jacket of cable coming from facility approximately 1 1/4”. Strip 1/4” of insulation from black and white lead wires.
 - iii. Connect wire to internal connectors on Female half of electrical connector, note color coded terminals designate power, neutral, and ground (brass, silver, green)
 - iv. Connect two halves of connector.
7. Install Foam Restrictor and Aspirator Shaft

NOTE: An aerator lying on its side would rest on the foam restrictor and bend the aspirator shaft or motor shaft. For this reason, it is necessary to either block up lower end of the aerator, or allow it to overhang an object during installation of aspirator shaft.

 - a. Slide foam restrictor down shaft until it stops at ground-step on aspirator shaft. Tighten set screw firmly. The Allen key should spring, but do not tighten it so much that it slips and rounds out the hex socket.
 - b. Slide aspirator shaft into coupling already attached to aerator motor shaft until foam restrictor stops against coupling. Firmly tighten the two set screws closest to foam restrictor. The Allen key should spring, but do not tighten it so much that it slips and rounds out hex socket.
 - c. To ease future disassembly, many distributors apply a light coating of lubricant, petroleum grease, to end of motor and aspirator shaft. If lubricant is applied do not use too much or allow it to get into the hollow end of the connector or shaft.
8. Fit Brackets - If the bumpers on the bottom brackets do not press against all sides of aerator riser, remove aerator and spring brackets out until all of them touch the sides. The fit should be snug, but not tight enough to push bumpers off when aerator is installed.
9. Install aerator in riser. If extension risers are used, it is easier to install or remove an aerator using a lift fork that is supplied in distributor’s tool kit. The lift fork can be screwed onto a piece of 1” threaded pipe (supplied by distributor). A 5’ length should be adequate for most installations. The lift fork should be positioned under the aerator lift handle.
10. Install Drip Loops. Once aerator is installed, push cable down below connector an inch or two. This forms a “drip loop” which channels any water running down the cable away from the aerator.
11. Rotate Aerator Clockwise. Looking down at installed aerator, rotate it clockwise until one of the mounting brackets engages the anti-rotation bolt. This prevents cutting off the air supply by twisting of the air hose and also eliminates electrical problems caused by twisted cables.

12. Place 4 ½" Outside-Air-Hose on hose adapter attached to aerator.

IMPORTANT: Hose must be in place to insure fresh air for optimum treatment and plant performance.

If one or more risers are used, a longer hose is required. Remove the air hose from the top of the aerator and cut a piece from a bulk coil (sold separately) and install it. It must be long enough to fit completely on the plastic hose adapter (top, center of aerator - over shaft) and go straight up into the center of the vent. Be sure hose is properly installed in vent cap. It must not be bent or kinked when the riser cover is replaced. After the riser cover is in place, remove the vent cap and check position of hose. It should be in the vent body but not close enough to the vent lid to restrict air flow.

13. Perform Electrical Test. The control panel installation and user's manual is provided with every Jet control panel. Read these before proceeding.
- Check to be sure the Control Panel installed is the correct one for the system and ensure that it includes an autodialer and pump lockout feature to disable discharge in the event of an alarm condition if required by local and state codes.
 - Check the wiring to be sure all the above instructions have been followed. If necessary, have the electrical contractor correct the work.
 - Set the Control Panel switch to the "OFF" position. Turn the power to the Control Panel circuit "ON" at the main panel. With the aerator installed and operational, there should be no audible or visual alarms.
 - Test for power to the panel. Use a multi-meter to confirm proper voltage to the panel and components. Operating voltages for the control circuit and aerator are 120 volts +/- 10%.
 - Check each circuit for proper polarity by placing one prod of the multi-meter on terminal and the other prod to the common wire in the Control Panel.
 - If the Control Panel is equipped with an auto dialer, program the autodialer according to the instructions provided. Trigger an alarm to confirm that the autodialer is functional and the land line has been activated.
 - Test the power to the pump circuit. If equipped with lock-out feature, initiate an alarm condition and confirm that the pump circuit power has been disabled. Return the alarm condition to normal setting.
 - If these tests or checks are not satisfactory, correct the wiring or contact an electrician.
 - When all checks are completed, make sure the Control Panel switch is in the "ON" position. Close and secure the Control Panel cover.
14. Observe Aerator Operation. It should be quiet and free from excessive vibration. Heavy vibration indicates shaft damage. If heavy vibration occurs, install a new shaft and return the shaft that is damaged to the factory.
15. Install aerator riser cover.
16. Final Steps.
- Completely fill in label on front of Control Panel cover.
 - Remove the red "Notice to Occupant" tag from Control Panel.
 - Fill in "Installation and Service Record" card.
 - Explain "Owner's Manual" to owner and wire manual to the Control Panel. Instruct owner to fill in "Owner Warranty Registration" card and mail it.
 - Record all installation information including address, date of start up, permit number, and status of contracts on the "Install Checklist".
 - Complete start up inspection and checklist and submit copies to Jet Inc. and the local administrative authority.

TANK PUMPING:

- Always pump down the pre-treatment tank first. The transfer tee in the baffle wall between the pre-treatment and treatment tank will allow water to move freely into the pre-treatment tank.
- After the pumping of the pre-treatment tank is complete, pump remaining liquid from the treatment tank and the clarifier.
- Fill the tank with water immediately after pumping, starting with the pre-treatment.

EFFLUENT TESTING:

1. Effluent Sample Means - Collection and assessment of effluent samples is required for all NSF Listed plants. There are four sample taking means from which samples may be taken. One of these methods must be chosen prior to plant installation and necessary arrangements made during installation to incorporate this method into the overall system. For information on "Collecting & Assessing Samples" see "Plant Inspection & Service" instructions. The means are as follows:
 - a. Final Outlet Samples - Can be taken at the final outlet point if it is accessible. The final outlet must be elevated sufficiently to allow a free-flowing sample to be taken.
 - b. Sample Cross Samples - The cross must be as close as possible to the discharge end of the tank. One horizontal arm of the cross should act as the first section of the discharge line from the tank. The other horizontal arm acts as a continuation of the discharge line. One vertical arm of the cross extends downward and the other extends up to grade. The arm to grade should be covered with a removable cover.
 - c. Distribution Box Samples - To use this method the box must have an inlet line high enough above the box floor so that a free-flowing sample can be taken. Also the top of the box must be slightly above grade and covered with a removable cover. If the box doesn't meet these qualifications it must be modified so that it does or this method of sample collection cannot be used.
 - d. Baffled Outlet Samples -- A sample from inside the plant outlet baffle may be taken. The outlet must have an open top and the plant discharge line must lead directly to it. It must also be accessible from grade and covered with a removable cover. Baffles are usually constructed with a plastic tee.

