

quality . service
innovation . integrity

150 Series



Features

The "Dose-Mate" series of submersible pumps is designed for use in residential or light commercial dewatering applications and can be used to transfer groundwater or effluent. These durable cast iron pumps include a powder coated epoxy finish to prevent corrosion and are designed to provide great heat dissipation from the motor, ensuring a long service life. As with every Zoeller pump, each one is 100% pressure-tested, submerged and run to ensure quality and reliability for years of trouble-free performance!

- Ideal for use in septic systems, low pressure pipe (LPP), and enhanced flow STEP system applications.
- Automatic models include a float-operated, two-pole mechanical switch, a stainless steel float guard and switch arm, and a solid, buoyant polypropylene float which prevents water from filling the float and causing a malfunction.
- For nonautomatic pumps, variable level control systems and containers of various sizes are available for longer cycles.
- Includes a stainless steel handle for easy installation and removal.
- All models are hermetically sealed to be watertight, dust-tight, and completely submersible.

Reserve Powered Design: For unusual conditions, a reserve safety factor is engineered into the design of every pump.

Specifications

Motor Characteristics

Motor	1/3 - 1/2 HP
Voltage	115 or 230 V
Phase	1 Ph
Hertz	60 Hz
RPM	3450 RPM
Type	Permanent split capacitor
Insulation	Class B
Amps	3.2 - 10.5 Amps

Pump Characteristics

Operation	Automatic or nonautomatic
Discharge Size	1-1/2" NPT
Solids Handling	151: 1/2" (13 mm), 152/153: 3/4" (19 mm) spherical solids
Cord Length	20' (6 m) standard
Cord Type	UL Listed power cord
Max Head	44' (13.4 m)
Max Flow Rate	77 GPM (291 LPM)
Max Operating Temp	130° F (54° C)
Cooling	Oil filled
Motor Protection	Auto reset thermal overload

Materials Characteristics

Cap	Cast iron
Motor Housing	Cast iron
Pump Housing	Cast iron
Base	Plastic or cast iron
Upper Bearing	Sleeve bearing
Lower Bearing	Ball bearing
Mechanical Seals	Carbon and ceramic
Impeller Type	Non-clogging vortex
Impeller	Engineered thermoplastic
Hardware	Stainless steel
Motor Shaft	AISI 1215 steel
Gasket	Neoprene



PUMP COMPANY

Zoeller Family of Water Solutions™

150 Series

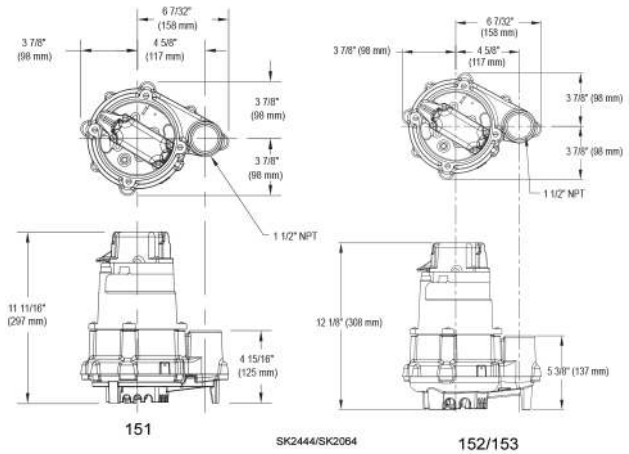
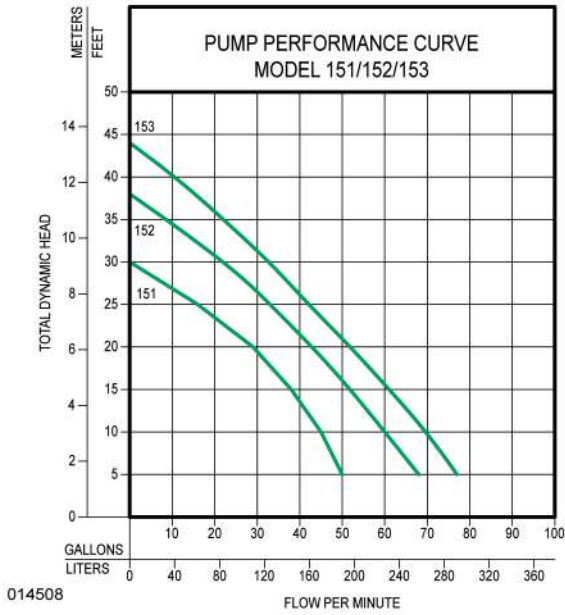

Model

Model Number	Seal	Mode	Volts	Phase	Amps	HP	Hz	Lbs	Kg
N151	Single	Non	115	1	6.0	1/3	60	32	15
E151	Single	Non	230	1	3.2	1/3	60	32	15
BN151	Single	Auto	115	1	6.0	1/3	60	33	15
BE151	Single	Auto	230	1	3.2	1/3	60	33	15
N152	Single	Non	115	1	8.5	0.4	60	37	17
E152	Single	Non	230	1	4.3	0.4	60	37	17
BN152	Single	Auto	115	1	8.5	0.4	60	39	18
BE152	Single	Non	230	1	4.3	0.4	60	39	18
N153	Single	Non	115	1	10.5	1/2	60	37	17
BN153	Single	Auto	115	1	10.5	1/2	60	39	18
E153	Single	Non	230	1	5.3	1/2	60	37	17
BE153	Single	Non	230	1	5.3	1/2	60	39	18

BN and BE models include a 20' (6 m) piggyback variable level pump switch. Additional cord lengths are available in 25' (8 m), 35' (11 m) and 50' (15 m).

Your Peace of Mind is Our Top Priority®
 3649 Cane Run Rd | Louisville, KY 40211 USA
 +1 502-778-2731 | 1-800-928-7867 | Fax: +1 502-774-3624
www.zoeller.com